

2 x 30W DUAL BRIDGE CAR RADIO AMPLIFIER

PRODUCT PREVIEW

- HIGH OUTPUT POWER CAPABILITY:
 - 2 x 30W max./4Ω @ 13.2V, 1KHz
 - 2 x 22W typ./4Ω @ 14.4V, 1KHz, 10%
 - 2 x 19W typ./4Ω @ 13.2V, 1KHz, 10%
 - 2 x 28W typ./2Ω @ 14.4V, 1KHz, 10%
 - 2 x 25W typ./2Ω @ 13.2V, 1KHz, 10%
- LOW DISTORTION
- LOW OUTPUT NOISE
- ST-BY FUNCTION
- MUTE FUNCTION
- AUTO-MUTE AT MIN. SUPPLY VOLTAGE DETECTION
- LOW EXTERNAL COMPONENT COUNT
 - INTERNALLY FIXED GAIN (32dB)
 - NO EXTERNAL COMPENSATION
 - NO BOOTSTRAP CAPACITORS
- ADDITIONAL MONO INPUT

PROTECTIONS:

- OUTPUT AC/DC SHORT CIRCUIT TO GND AND TO V_S
- VERY INDUCTIVE LOADS
- OVERRATING CHIP TEMPERATURE WITH SOFT THERMAL LIMITER
- LOAD DUMP VOLTAGE

BLOCK DIAGRAM

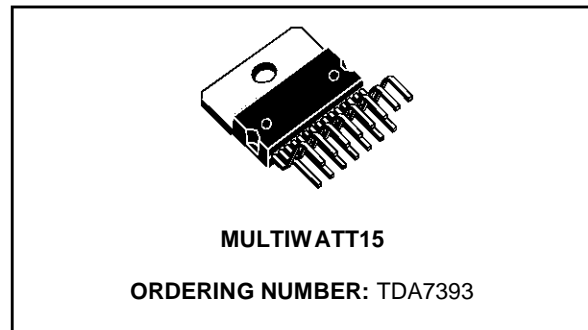
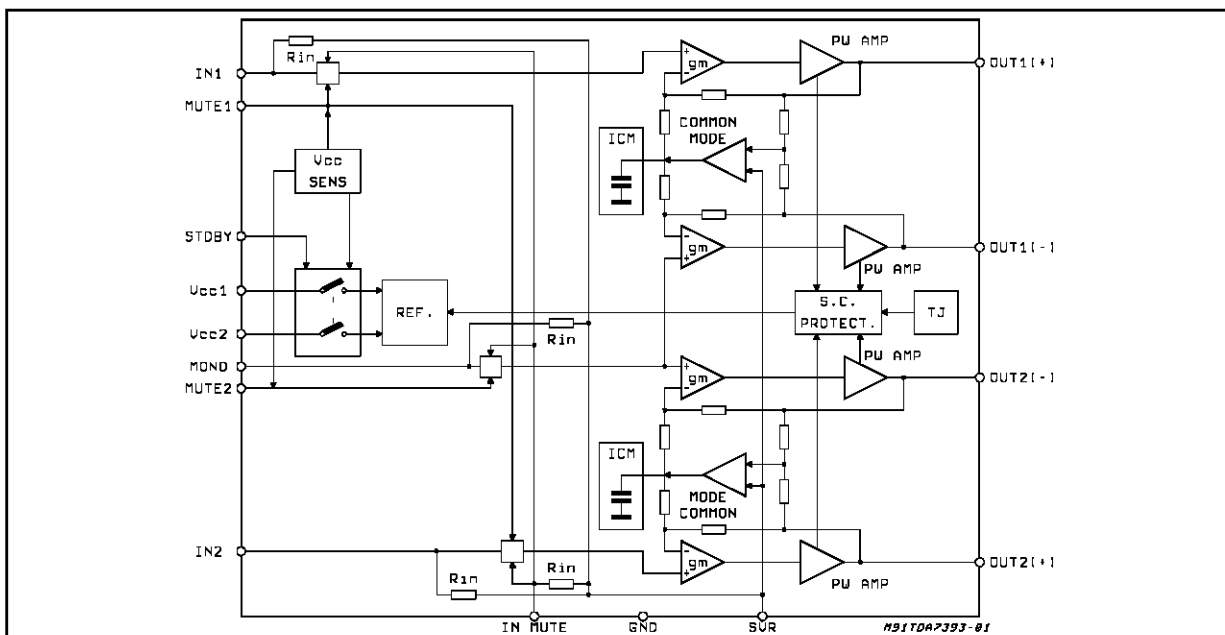

- FORTUITOUS OPEN GND
- REVERSE BATTERY
- ESD PROTECTION

DESCRIPTION

The TDA7393 is a new technology class AB Audio Power Amplifier in Multiwatt15 package designed for high end car radio applications. Thanks to the fully complementary PNP/NPN output configuration the high power performances of the TDA7393 are obtained without bootstrap capacitors. The extremely reduced components count allows very compact sets.

TDA7393

ABSOLUTE MAXIMUM RATINGS

Symbol	Parameter	Value	Unit
V _{CC}	Operating Supply Voltage	18	V
V _{CC (DC)}	DC Supply Voltage	28	V
V _{CC (pk)}	Peak Supply Voltage (t = 50ms)	50	V
I _O	Output Peak Current: Repetitive (Duty Cycle 10% at f = 10Hz) Non Repetitive (t = 100μs)	4.5 5.5	A A
P _{tot}	Power dissipation, T _{case} = 75°C (see derating curve)	50	W
T _j	Junction Temperature	150	°C
T _{op}	Operating Ambient Temperature	- 40 to 85	°C
T _{stg}	Storage Temperature	- 55 to 150	°C

PIN CONNECTION (Top view)

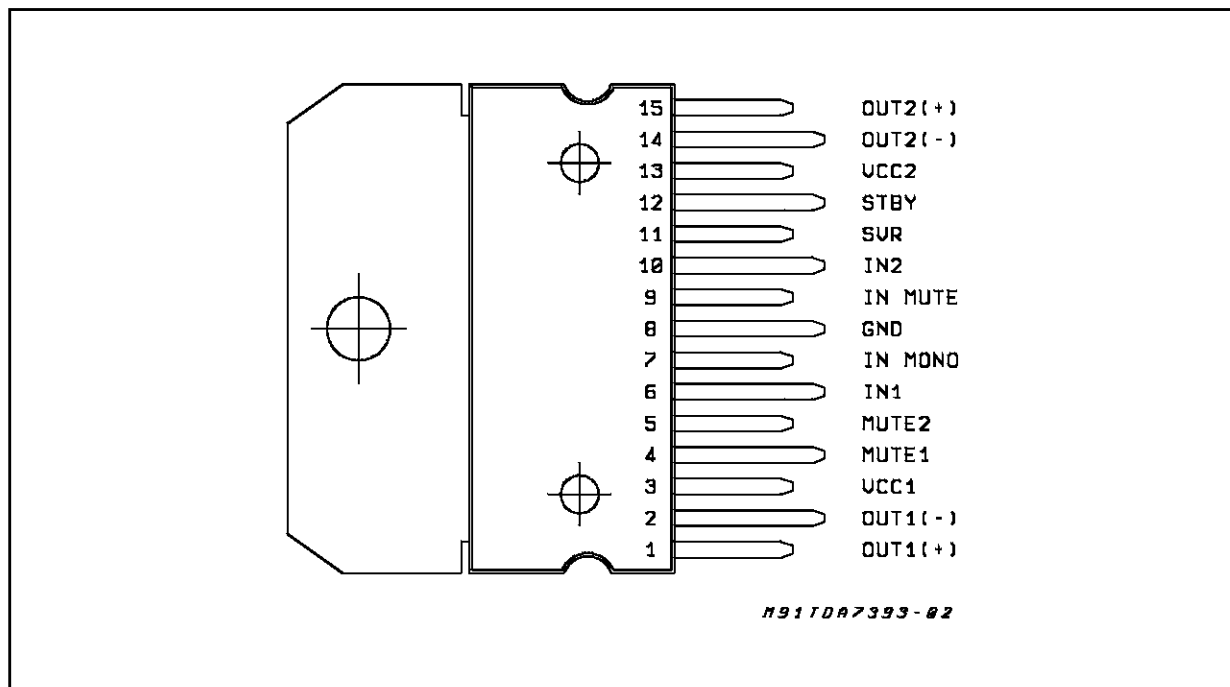

THERMAL DATA

Symbol	Parameter	Value	Unit
R _{th j-case}	Thermal Resistance Junction to Case	Max. 1.5	°C/W

ELECTRICAL CHARACTERISTICS ($V_S = 13.2V$; $f = 1KHz$; $R_G = 600\Omega$; $R_L = 4\Omega$; $T_{amb} = 25^\circ C$;
Refer to the application circuit, unless otherwise specified.)

Symbol	Parameter	Test Condition	Min.	Typ.	Max.	Unit
I_{q1}	Quiescent Current			90	180	mA
V_{OS}	Output Offset Voltage				150	mV
G_V	Voltage Gain		30.5	32	33.5	dB
P_o	Output Power	THD = 10%; $V_S = 14.4V$ THD = 10% THD = 1% THD = 10%; $R_L = 2\Omega$ THD = 10%; $V_S = 14.4V$; $R_L = 2\Omega$	17	22 19 16 25		W W W W W
$P_{o\ max}$	Max. Output Power	EIAJ RULES; $V_S = 13.7V$		30		W
THD	Distortion	$P_o = 0.1$ to $8W$		0.08	0.3	%
e_{No}	Output Noise	$Bw = 20Hz$ to $20KHz$			0.3	mVrms
SVR	Supply Voltage Rejection	$f = 100Hz$ (stereo)		60		dB
f_L	Low Cut-Off Frequency			10		Hz
f_H	High Cut-Off Frequency			300		KHz
R_i	Input Impedance		10	15	20	K Ω
C_T	Cross Talk	$f = 1KHz$	50	65		dB
I_{SB}	St-By Current Consumption				100	μA
$V_{SB\ out}$	St-By OUT Threshold Voltage	Amp. ON	3.5			V
$V_{SB\ in}$	St-By IN Threshold Voltage	Amp. OFF			1.5	V
V_{SB}	Supply Dependent St-By Threshold	St-By = H, V_S reducing/increasing		7.5	8.3	V
A_M	Mute Attenuation	$V_O = 1V_{rms}$		75		dB
$V_{M\ out}$	Mute OUT Threshold Voltage	Amp. Play	3.5			V
$V_{M\ in}$	Mute IN Threshold Voltage	Amp. Mute			1.5	V
V_M	Supply Dependent Mute Threshold	Mute = IN, V_S reducing/increasing		8.5	9.3	V
$I_m (L)$	Muting Pin Current	$V_{MUTE} = 1.5V$ (Sourced Current)	6	10	14	μA
$I_m (H)$	Muting Pin Current	$V_{MUTE} = 3.5V$ (Sourced Current)	6	10	14	μA

Figure 1: Quiescent Current vs. Supply Voltage

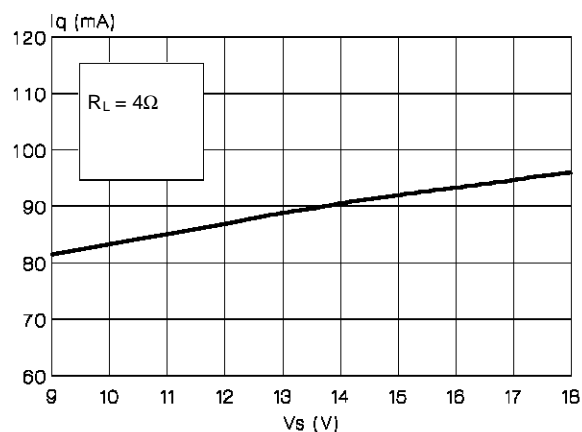

Figure 2: Output Power vs. Supply Voltage

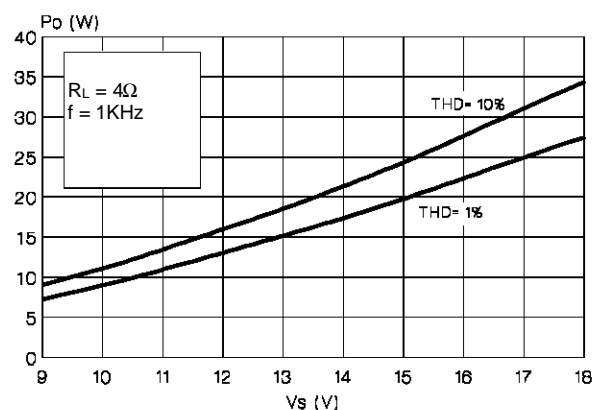

Figure 3: Output Power vs Supply Voltage

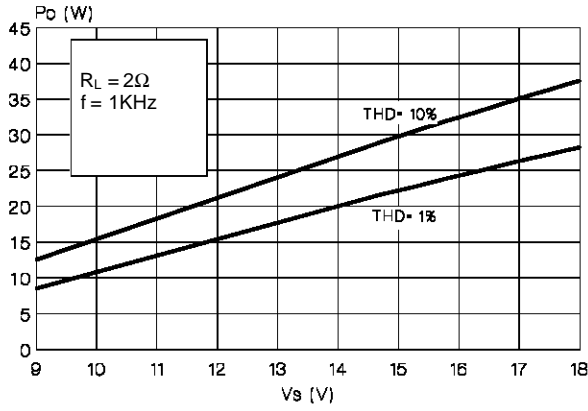

Figure 4: EIAJ Power vs. Supply Voltage

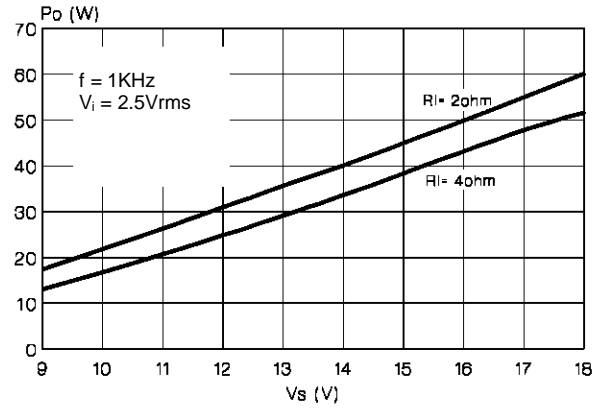

Figure 5: Cross-Talk vs. Frequency

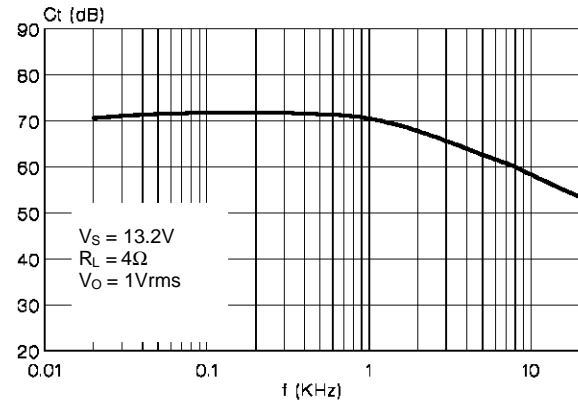

Figure 6: SVR vs. Frequency

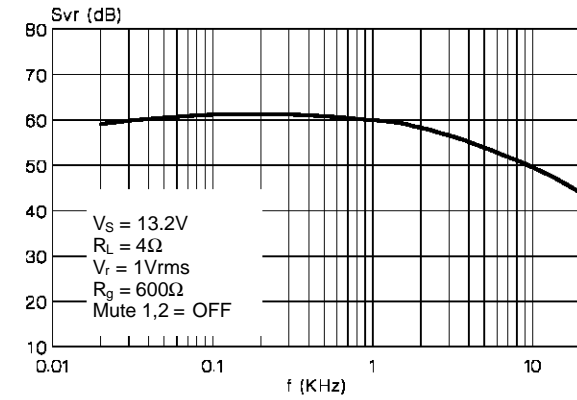

Figure 7: Distortion vs. Frequency

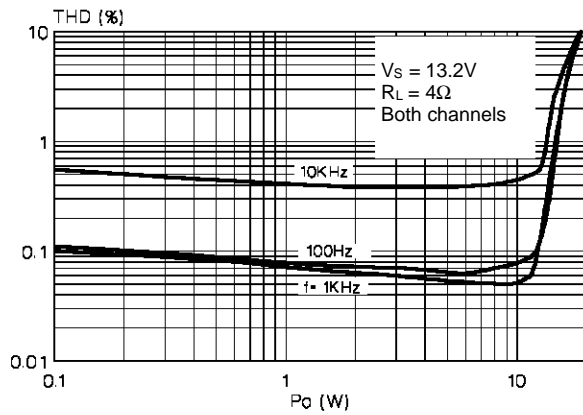

Figure 8: Distortion vs. Frequency

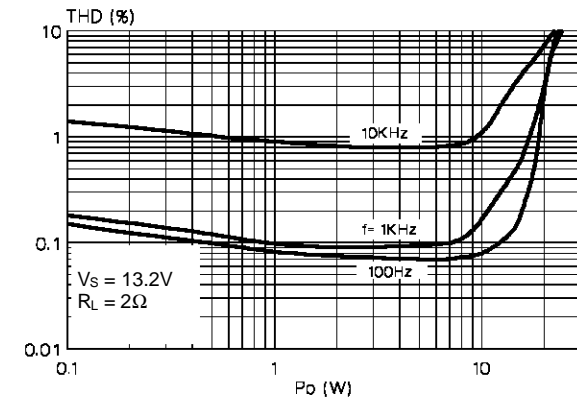

Figure 9: Block Diagram of Mute Circuit

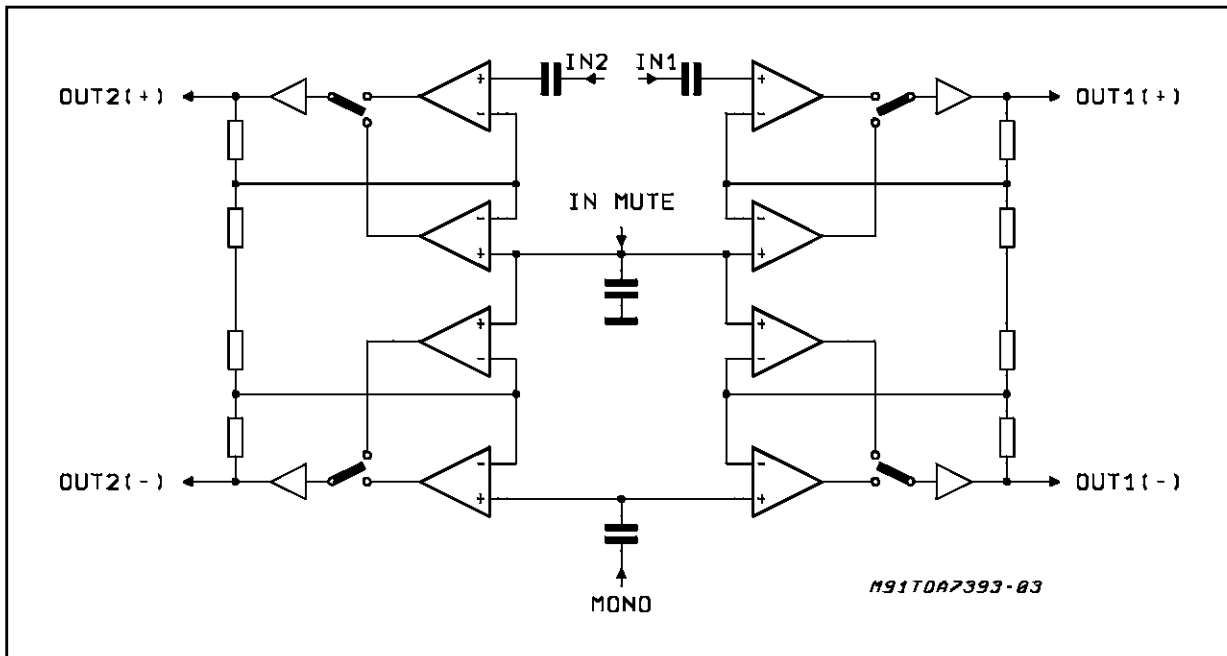

Figure 10: Explanatory Waveforms Of Mute Circuit

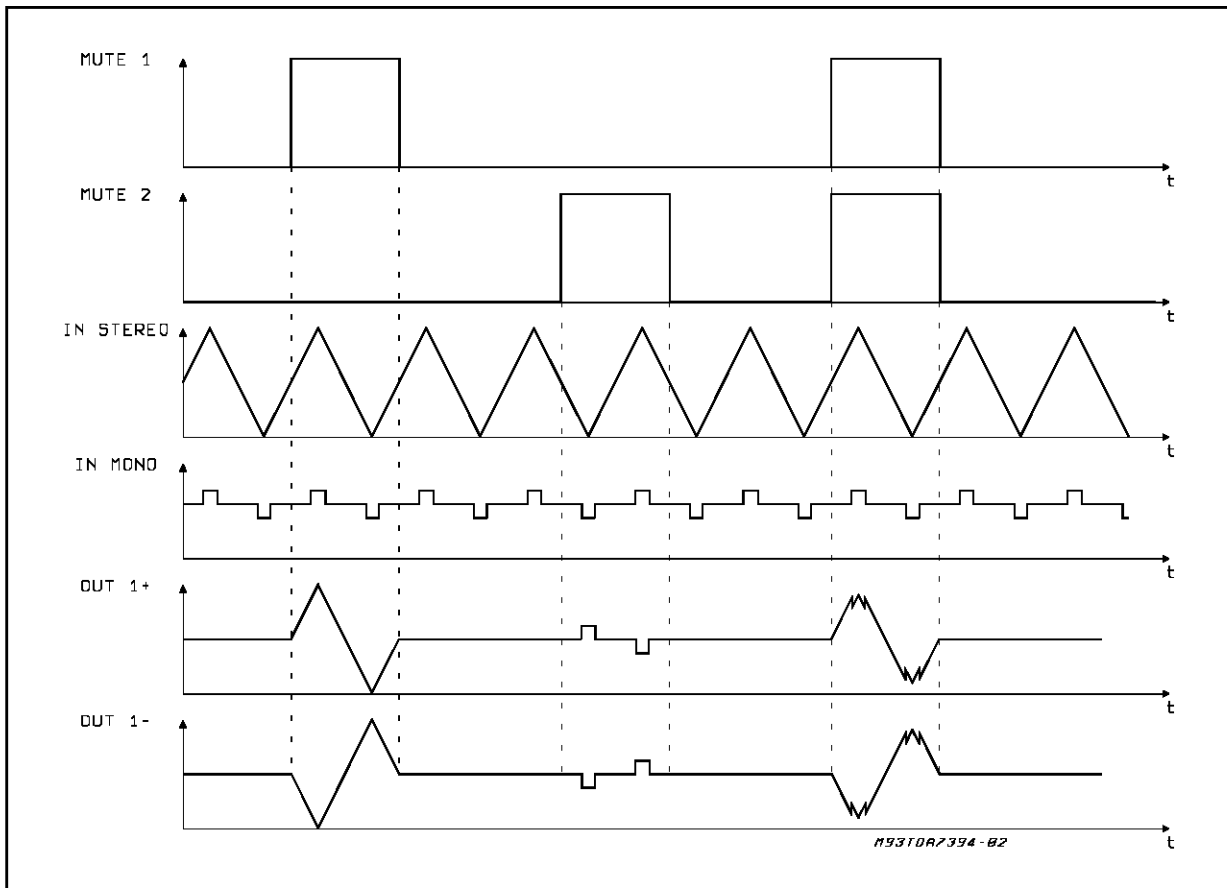

Figure 11: Application Circuit

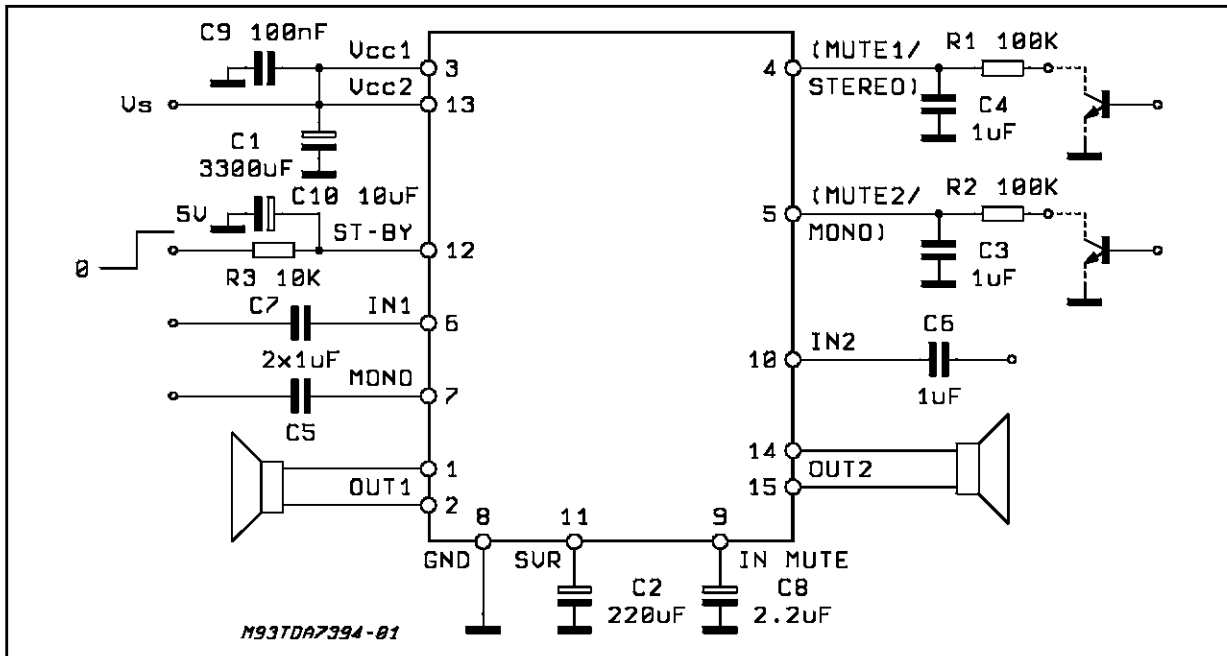

Figure 12: P.C. Board and Component Layout of the fig. 11 (1:1 scale)

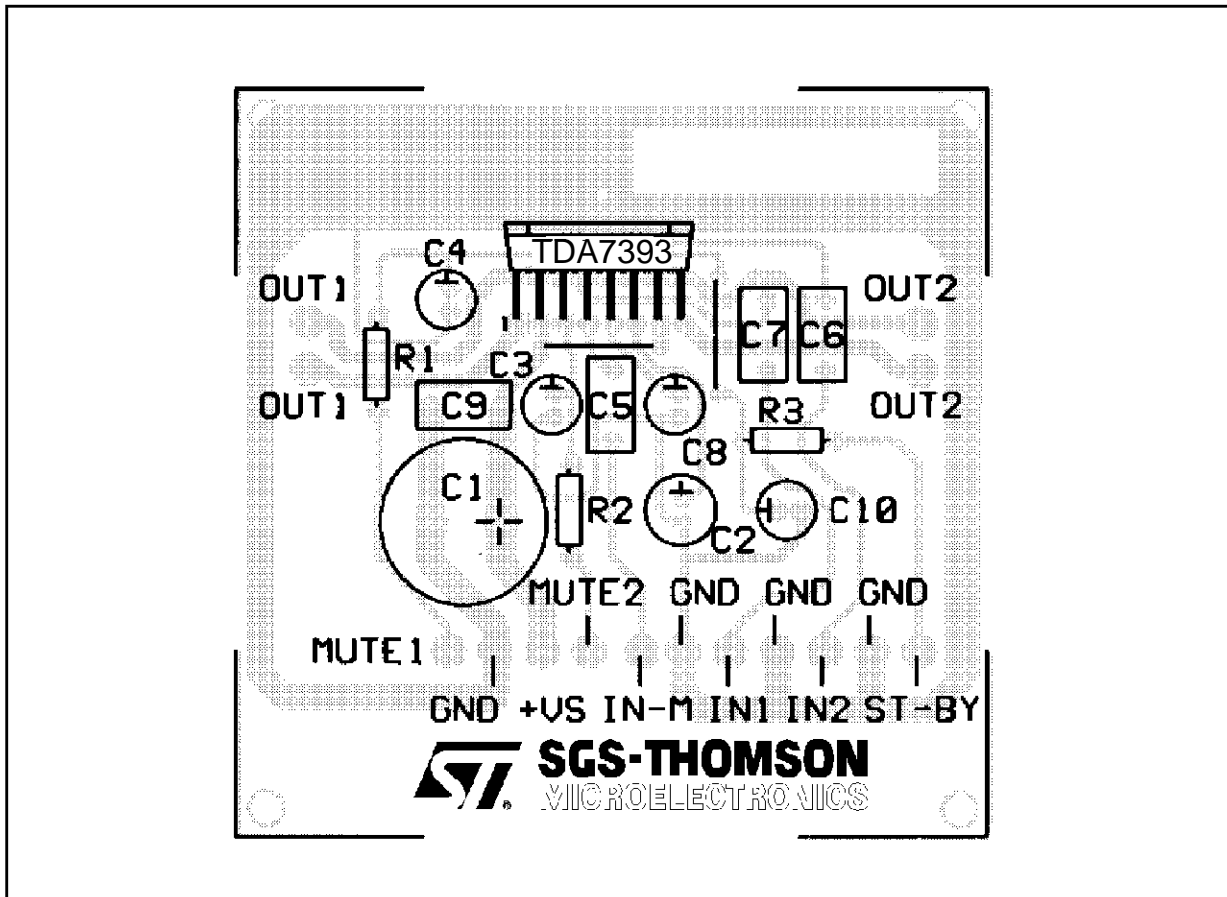
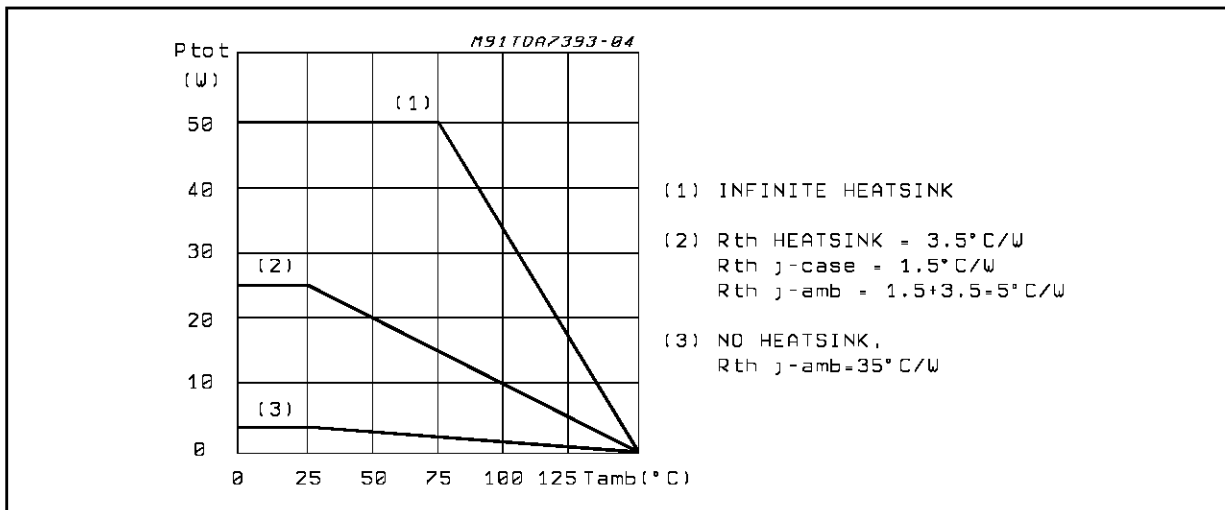
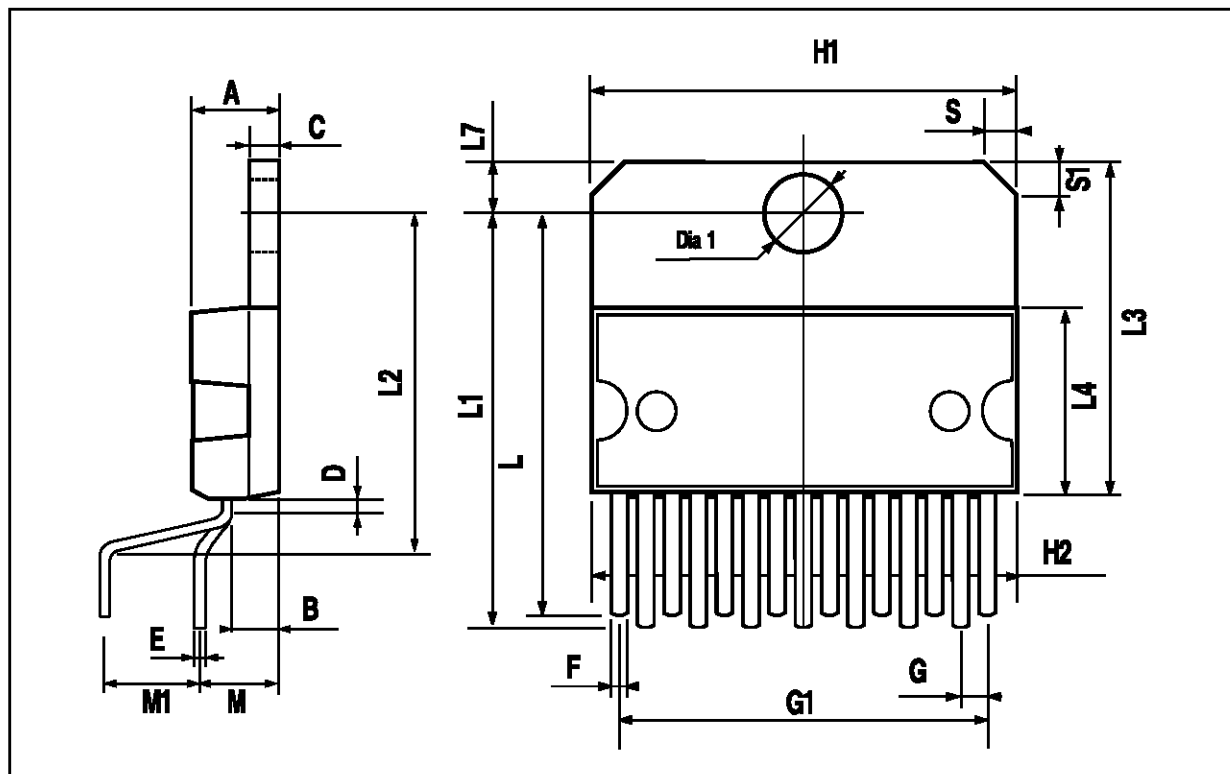

Figure 13: Power Dissipation Derating Curve



MULTIWATT15 PACKAGE MECHANICAL DATA

DIM.	mm			inch		
	MIN.	TYP.	MAX.	MIN.	TYP.	MAX.
A			5			0.197
B			2.65			0.104
C			1.6			0.063
D		1			0.039	
E	0.49		0.55	0.019		0.022
F	0.66		0.75	0.026		0.030
G	1.14	1.27	1.4	0.045	0.050	0.055
G1	17.57	17.78	17.91	0.692	0.700	0.705
H1	19.6			0.772		
H2			20.2			0.795
L	22.1		22.6	0.870		0.890
L1	22		22.5	0.866		0.886
L2	17.65		18.1	0.695		0.713
L3	17.25	17.5	17.75	0.679	0.689	0.699
L4	10.3	10.7	10.9	0.406	0.421	0.429
L7	2.65		2.9	0.104		0.114
M	4.2	4.3	4.6	0.165	0.169	0.181
M1	4.5	5.08	5.3	0.177	0.200	0.209
S	1.9		2.6	0.075		0.102
S1	1.9		2.6	0.075		0.102
Dia1	3.65		3.85	0.144		0.152



Information furnished is believed to be accurate and reliable. However, SGS-THOMSON Microelectronics assumes no responsibility for the consequences of use of such information nor for any infringement of patents or other rights of third parties which may result from its use. No license is granted by implication or otherwise under any patent or patent rights of SGS-THOMSON Microelectronics. Specifications mentioned in this publication are subject to change without notice. This publication supersedes and replaces all information previously supplied. SGS-THOMSON Microelectronics products are not authorized for use as critical components in life support devices or systems without express written approval of SGS-THOMSON Microelectronics.

© 1995 SGS-THOMSON Microelectronics - All Rights Reserved
MULTIWATT® is a Registered Trademark of the SGS-THOMSON Microelectronics

SGS-THOMSON Microelectronics GROUP OF COMPANIES
Australia - Brazil - France - Germany - Hong Kong - Italy - Japan - Korea - Malaysia - Malta - Morocco - The Netherlands - Singapore -
Spain - Sweden - Switzerland - Taiwan - Thailand - United Kingdom - U.S.A.